



**UTM**  
UNIVERSITI TEKNOLOGI MALAYSIA

SCHOOL OF MECHANICAL  
ENGINEERING

*i2me*

# WEEK 7



# VISUAL & DIGITAL COMMUNICATION

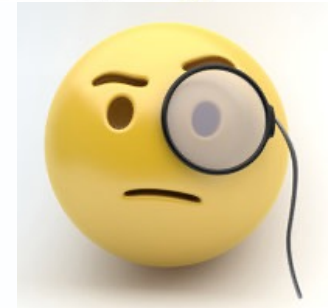

Zed

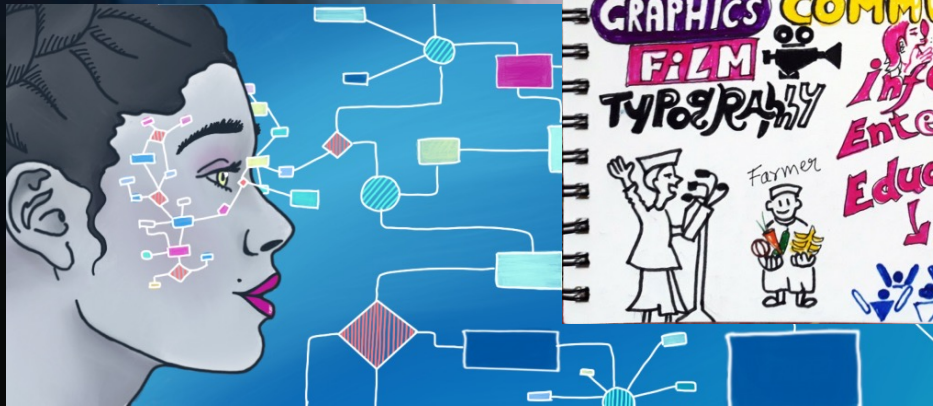

# LEARNING OUTCOME

**Ability to prepare presentations using visual and digital media**

# VISUAL & DIGITAL COMMUNICATION

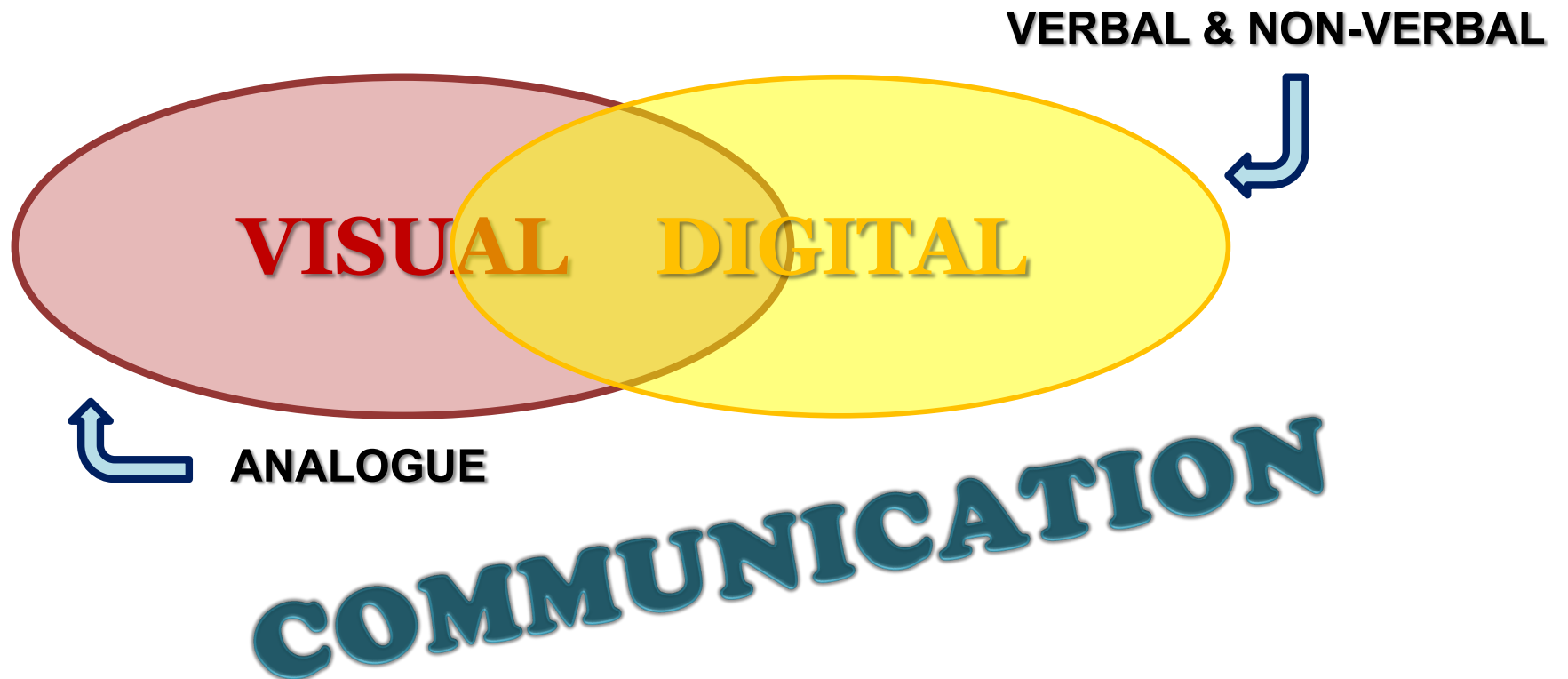

# VISUAL COMMUNICATION

Visual communication is a method of exchanging information and ideas through visually appealing imagery and symbols.

It also include the photographs, illustrations, graphics, film, typography, gestures etc. And many other mediums are available to communicate your message.

It is just like sending and giving information in an interesting way in which people can take interest or participate.

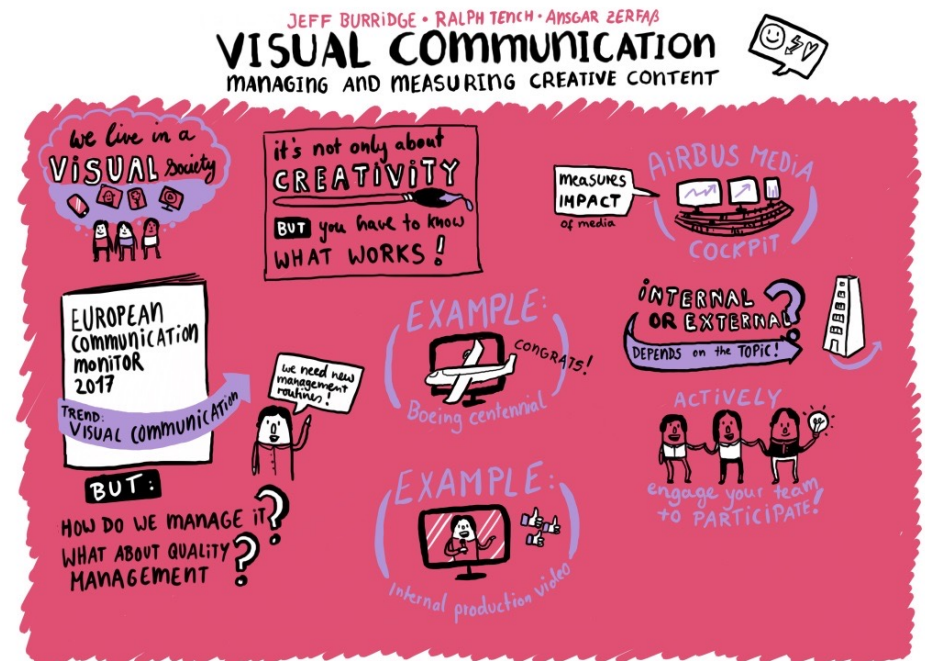

# VISUAL COMMUNICATION

## Methods of Communication:

There are three types of communication



**1. Visual Communication:** Image, illustration, photograph, film, gestures, expressions etc.

**2. Verbal Communication:** Oral or speaking



**3. Non Verbal Communication:** tone, gestures, face expressions, body language etc.



# VISUAL COMMUNICATION

## COMMUNICATION

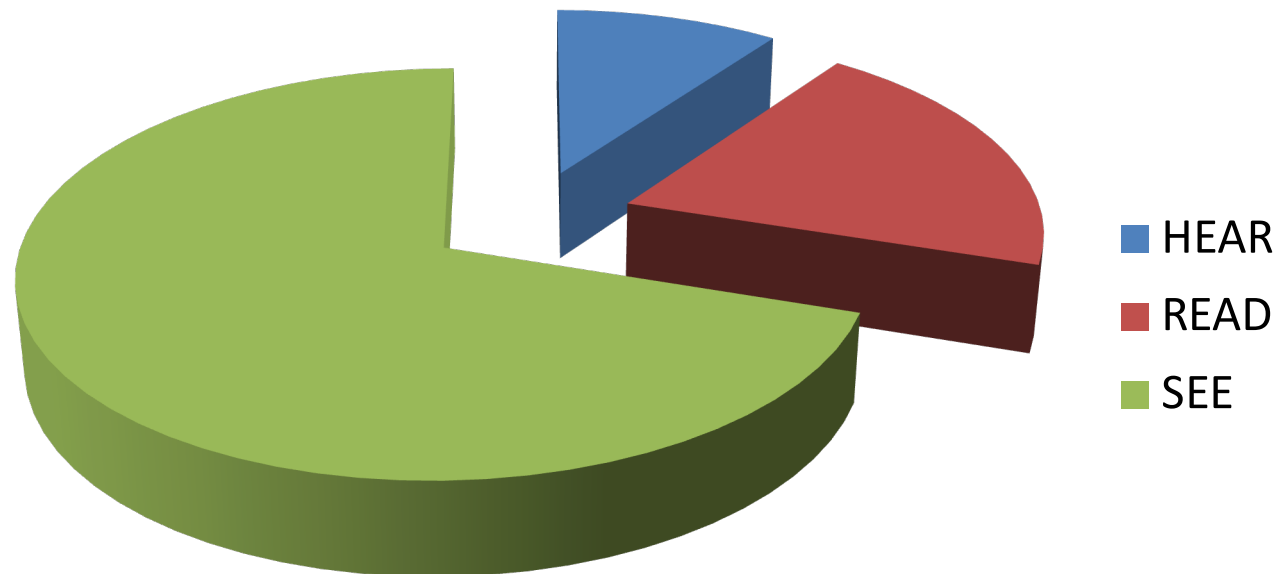

*However People rely on the visual communication most, and believed to be the best method of communicating each other. Studies show that almost 10% -12% people remember what they hear, 20% – 25% what they read and 70%-80% of people remember what they see. So you can understand which is the most interesting way of communication.*

# VISUAL COMMUNICATION

## VISUAL ELEMENTS:

**OBJECTS**

**MODELS**

**GRAPHS**

**MAPS**

**TABLES**

**PHOTOGRAPHS**

**DRAWINGS OR  
DIAGRAMS**



Stress-Strain diagram for mild steel

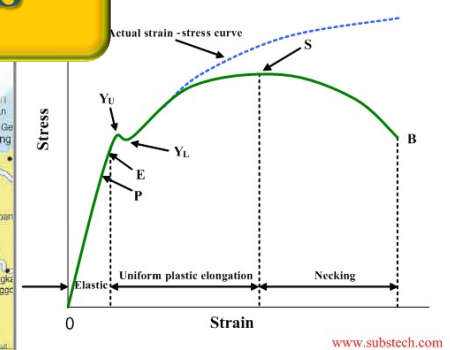

Total Bending Moment of Aluminum Dial Tables, between 1/4 Inch and 2 Inches thick.

Diameter in	1/4 Plate lb.in Mtotal	1/2 Plate lb.in Mtotal	3/4 Plate lb.in Mtotal	1 Plate lb.in Mtotal	1.25 Plate lb.in Mtotal	1.5 Plate lb.in Mtotal	1.75 Plate lb.in Mtotal	2 Plate lb.in Mtotal
12	-5	-11	-16	-21	-27	-32	-38	-45
18	-29	-57	-86	-114	-143	-171	-200	-230
24	-65	-130	-194	-259	-324	-389	-454	-520
30	-152	-304	-456	-608	-760	-912	-1,064	-1,216
36	-228	-457	-685	-913	-1,142	-1,370	-1,598	-1,827
42	-304	-608	-913	-1,216	-1,519	-1,822	-2,125	-2,428
48	-380	-760	-1,142	-1,519	-1,822	-2,125	-2,428	-2,731
54	-457	-913	-1,370	-1,743	-2,125	-2,507	-2,889	-3,271
60	-533	-1,064	-1,598	-2,026	-2,408	-2,790	-3,172	-3,554
66	-609	-1,216	-1,822	-2,309	-2,691	-3,073	-3,455	-3,837
72	-685	-1,370	-2,042	-2,592	-3,073	-3,455	-3,837	-4,219
78	-760	-1,519	-2,263	-2,875	-3,356	-3,738	-4,120	-4,502
84	-836	-1,672	-2,484	-3,158	-3,639	-4,020	-4,402	-4,784
90	-912	-1,822	-2,705	-3,441	-3,922	-4,302	-4,684	-5,066
96	-988	-1,975	-2,926	-3,724	-4,205	-4,587	-4,969	-5,351
102	-1,064	-2,125	-3,147	-4,007	-4,488	-4,969	-5,351	-5,733
108	-1,140	-2,278	-3,368	-4,290	-4,771	-5,252	-5,634	-6,016
114	-1,216	-2,431	-3,589	-4,573	-5,054	-5,534	-5,916	-6,298
120	-1,292	-2,584	-3,810	-4,856	-5,337	-5,817	-6,199	-6,581

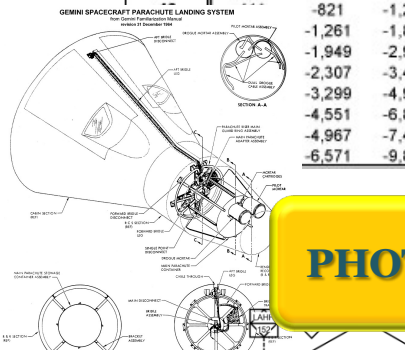

**Q**

**Discuss the pros & cons of using each of these elements**

# VISUAL COMMUNICATION

## VISUAL AIDS MEDIA:





# DIGITAL COMMUNICATION

## THE DIGITAL REVOLUTION

In the years since the invention of the first digital computers, computing power and storage capacity have increased exponentially. Personal computers and smartphones put the ability to access, modify, store and share digital media in the hands of billions of people.

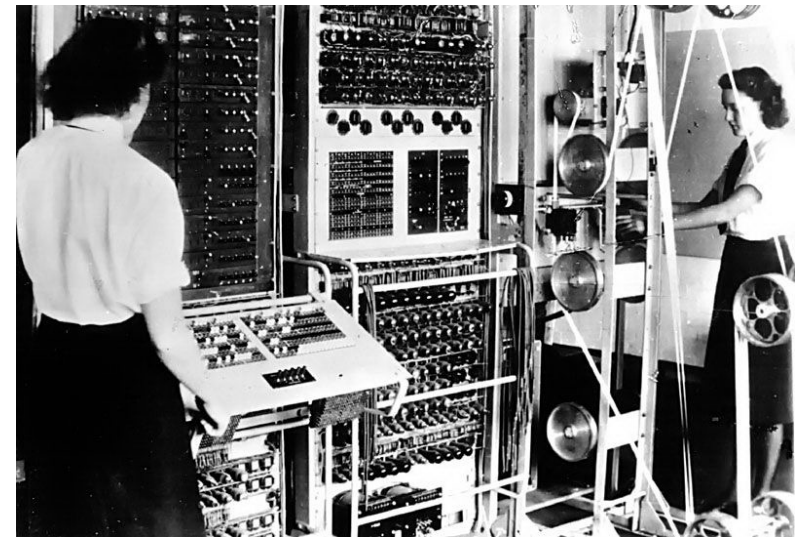

# DIGITAL COMMUNICATION

## THE DIGITAL REVOLUTION

Many electronic devices, from [digital cameras](#) to [drones](#) have the ability to create, transmit and view digital media. Combined with the [World Wide Web](#) and the [Internet](#), digital media has transformed 21st century society in a way that is frequently compared to the cultural, economic and social impact of the [printing press](#).



# DIGITAL COMMUNICATION

## THE DIGITAL REVOLUTION



The change has been so rapid and so widespread that it has launched an economic transition from an industrial economy to an information-based economy, creating a new period in human history known as the Information Age or the digital revolution.



# DIGITAL COMMUNICATION

## THE DIGITAL REVOLUTION

Q

**Discuss the pros & cons of  
E-Learning**



# DIGITAL COMMUNICATION



**EDITING...  
PRESENTATION...  
DATABASE ACCESS...  
MANY MORE...**



**RENDERFOREST**  
online video maker

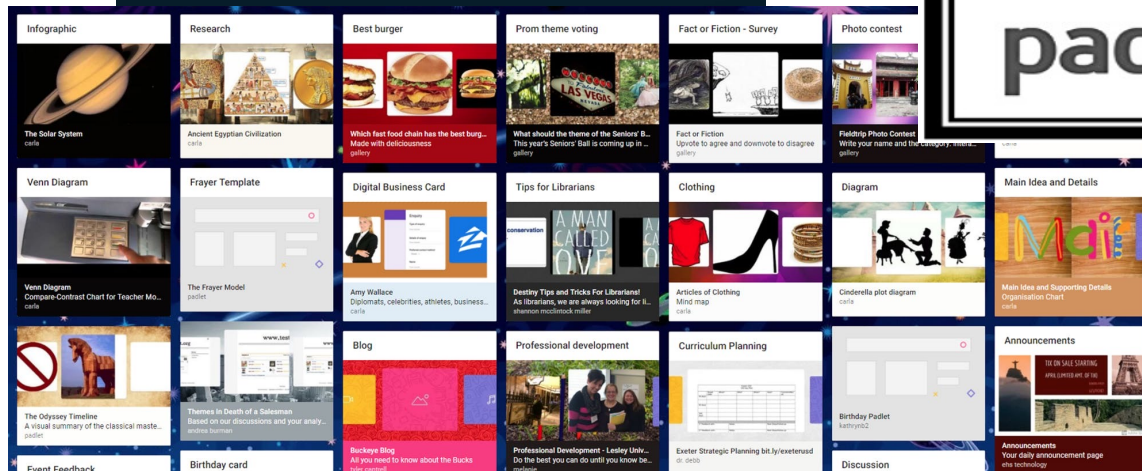



**UTM**  
UNIVERSITI TEKNOLOGI MALAYSIA

SCHOOL OF MECHANICAL  
ENGINEERING

*i2me*

**WEEK 7**

**THANK YOU**

